



# NBK2 SERIES BROCHURE

BOOST MODE <b>AUTO</b>	BOOST STATUS <b>ON</b>	BOOST %   XFMR <b>12.5 50A</b>
SHORE POWER INPUT <b>196 V</b>	XFMR OUTPUT <b>220 V</b>	PRIMARY CURRENT <b>20 A</b>
kWh METERING <b>1203 kWh</b>	WiFi STATUS Connected <b>nbk-32A30</b>	ALARM STATUS <b>None</b>
INFO <b>V.13520</b> 00:0a:35:9a:68:16	STATUS <b>wifi config</b>	TEMPERATURE <b>74 F</b>



**Smart Auto Boost  
Controller System**

Auto-Boost Voltage controller



Shore Power Combiner & Load Shedding (Parallel shore cords)



## ISOBOOST AUTO CONTROLLER

Compatible with any IsoBoost transformers

Nauti-Tech latest Auto-Boost voltage controller provides the capability to turn your regular isolation transformer into a smart automatic boost transformer. This means you can always be sure to have the most efficient and safe power when you need it. Even when you are not around, our voltage controller will monitor shore power voltage conditions for you to keep your boat safe. No more worrying about docks shore power conditions, because whether it is low voltage, or high voltage our controller will ensure protection of all your marine electronic equipment. Pair this along with our shore power combiner modules and you will have complete control and monitoring of your vessel.



### Kwh Monitoring

Provides accurate energy consumption metering (kWh), with resettable counter allowing users to identify how much energy was consumed during different periods.



### Retrofit All Transformers

Compatible with any transformer, any brand with boost coils. Also compatible with all Iso-boost transformers and other Charles products isolation transformer.



### WI-FI/ LAN

Users can configure as AP mode or connect to their existing networks and use our enriched mobile or desktop interface to monitor, configure or control your transformers.

## Touchscreen HMI

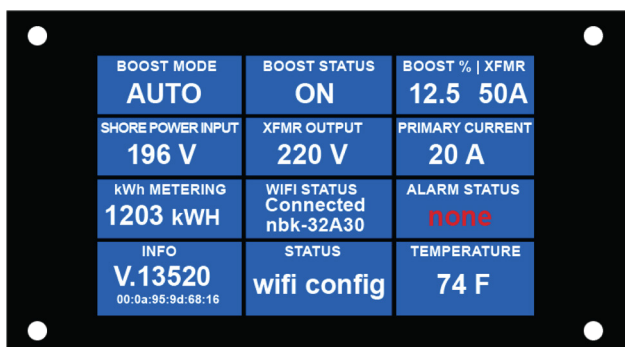

### 3.5" HMI touchscreen with IoT dashboard

Take control with our HMI dashboard which allows full boost controls right at your fingertips. It includes every valuable data from your transformer including temperature, boost ratio, shore power input and kWh readings. This screen can be extended using cat 5 up to 300ft.

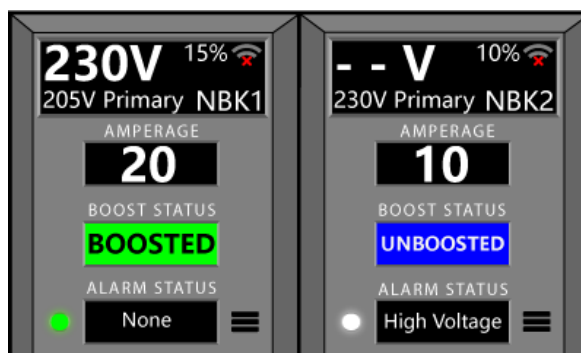

### Control up to 2 transformers

With our NBK2 Series you can now control up to 2 transformers all from the same HMI screen. The double transformer screen allows you to see your transformer's values and boost status including alarm and an LED indicator for alarms and events.

# RGB Alarm

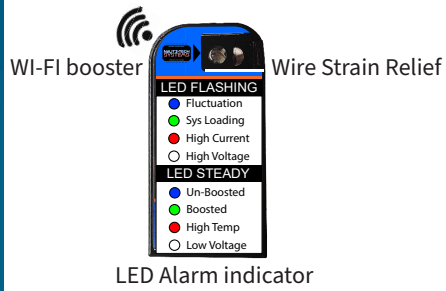

## RGB Status indicator

Visually inspect status of your boost or any alarms directly from transformer. Extend your wifi capabilities with built in wifi antenna. Functions also as a wire strain relief for your cat 5 cable.

# Mobile Access

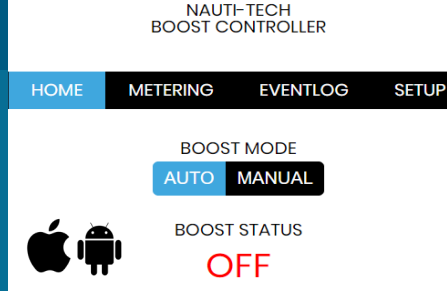

## Control Boost via your phone

With our enriched HTML page you can view, control all your boost controller from your mobile phone or via your computer on the network

# EventLog

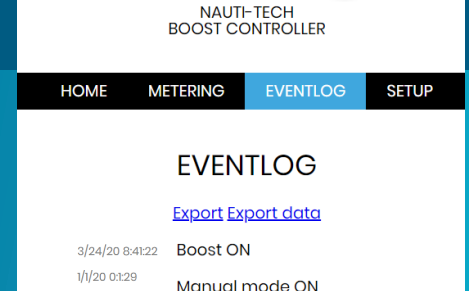

## Full Event Log at your fingertips

Event Log page stores all of your events. It will keep a total of 100 events stored, max of 10 pages. Once reached to 100 events, it will overwrite from the beginning (page1)

# Retrofit Kit Obsolete PM3™



HEADLESS		ISO-BOOST	
<b>NBK2-HDL</b>	<b>NBK2</b>	<b>NBK2A / NBK2B</b>	<b>NBK2A-SC / NBK2B-SC</b>
1* mainboard 1* hardware set	1* 3.5inch HMI 1* mainboard 1* hardware set	1* mainboard 1* contactor 1* hardware set	1* 3.5inch HMI 1* mainboard 1* contactor 1* hardware set

# Retrofit Any Brand



<b>NBK2-TBO25</b>	<b>NBK2-TBO15</b>
1* NBK2 1* Boosting Transformer 1* Contactor (25kVa version)	1* NBK2 1* Boosting Transformer 1* Contactor (15kVa version)

# Retrofit Shore Power

## Shore Power Complete Solution

Nauti-Tech Systems is also proud to introduce the Nauti-Combiner© series + NBK2 retrofit solutions. Offering the most complete system to enhance, manage & safely stabilize the power demands & distribution on your vessel.

Our Retrofit kit can replace your old obsolete Charles PM3™ systems all while maintaining your existing wiring. Our combiner is available in multiple configurations for your convenience. This series allows the combining of two shore power isolation transformers into a single higher current AC voltage bus with ease. Whether you are docked, or offshore, the Combiner will help keep your power needs satisfied all while providing some of the most advance safety features out on the market. (See diagram in next page)

Take advantage of complete shore power and boost controller kit with features like:

- Shore Power parallel combining
- Single or Dual Load Bus configurations
- Load Shedding
- Transformer Boost control
- HMI Daisy chainable touch screen display
- Mobile access for boost controller (NBK2)

[www.nauti-tech.systems](http://www.nauti-tech.systems)

# All in one complete PM3 Retrofit Solution

## Shore Combiner & Transformer Auto Boost Retrofit Solution NBK2+SPM

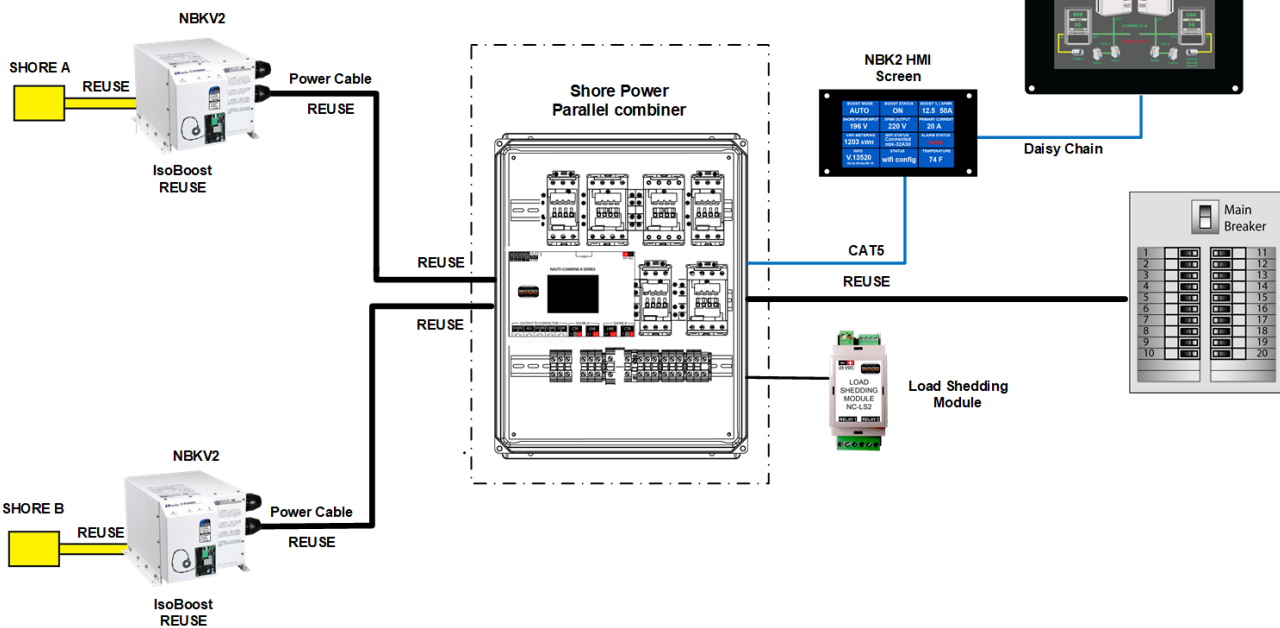

## Any brand, complete transformer Retrofit & Paralleling Solutions

## Shore Combiner & Transformer Auto Boost Retrofit Solution NBK2+SPM

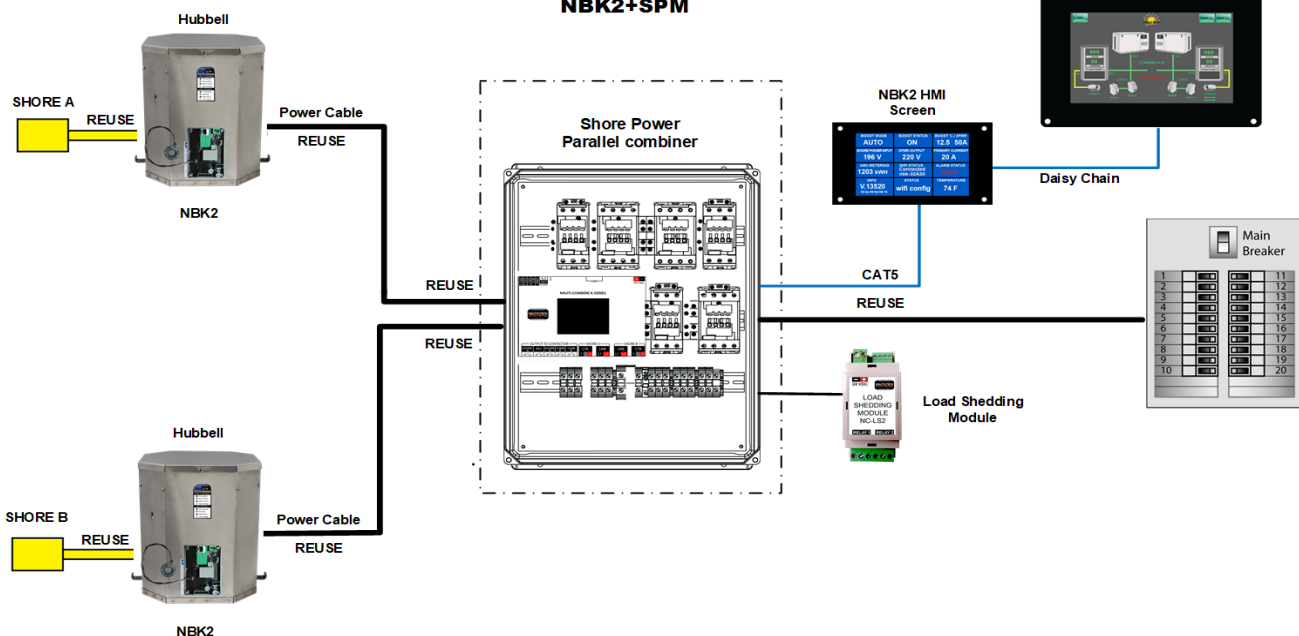

## Contact Us

3219 South Andrews Ave

Ft. Lauderdale 33316

info@nauti-tech.com

<http://www.nauti-tech.systems>

